



## Toyota Fortuner MY2021 on Predator & Toro Front Bar

### **IMPORTANT! – READ BEFORE INSTALLATION**

- When installed in accordance with these instructions, the front protection bar does not affect the operation of the vehicles SRS airbags.
- This product must be installed exactly as per these instructions using only hardware supplied.
- Take a few moments to read instructions thoroughly before beginning work.
- In the event of damage to any bar component please contact OFFROAD ANIMAL to arrange repair/replacement of components.
- Do not use this product for any vehicle make or model other than that specified on these instructions.
- Do not remove labels from this product.
- This product and its fixings must not be modified in any way unless stated in these fitting instructions.
- The installation of this product is recommended for trained personnel.
- These instructions are correct at time of publication. OFFROAD ANIMAL cannot be held responsible for the impact of any changes subsequently made by the vehicle manufacturer. If you find something has changed please contact us to let us know!
- During installation it is the duty of the installer to check correct operation/clearances of all components.
- If Instructions are to be printed for reference in the workshop, it is recommended that they are printed in colour, for best legibility.

## GENERAL CARE AND MAINTENANCE

Use caution when cleaning with pressure washers, as they may compromise the product coating's integrity. Exercise care to avoid surface damage.

Only wash the product with a PH neutral car wash to prevent paint damage and discolouration.

Do not use acidic or alkaline based cleaning products.

Plastic parts may be maintained with silicone spray.

It is important to perform regular checks (pre/during/post trip or on an annual basis) on the installed product. More frequent checks may be required in extreme use cases. Checks include:

- Visual inspection for damage (eg. cracks, chips, dents etc.)
- Electrical wiring is not rubbing anything or worn out
- Bolts are torqued to correct specification (see torque guide below)

For touching up small stone chips, Offroad Animal recommends the following paint products:

- Dupli-Color Trim & Bumper Paint Black (TB101)
- VHT Hood, Bumper & Trim Paint Black (SP27)

## BOLT TORQUE SETTINGS

Use the following bolt torques on all general fasteners, unless otherwise specified.

GENERAL FASTENERS	
Size	Torque Nm
M5	5 Nm
M6	9 Nm
M8	22 Nm
M10	44 Nm
M12	77 Nm

Use the following bolt torques on all structural front bar mount and tow point fasteners, and rear towbar fasteners, unless otherwise specified.

FRONT BAR MOUNTS AND TOW POINTS + REAR TOWBAR	
Size	Torque Nm
M10	57 Nm
M12	100 Nm
M14	164 Nm
M16	248 Nm

**Always use a torque wrench to set correct torque settings. Ensure torque wrench is set to Nm unit of measurement. Otherwise perform conversion to lb-ft.**

# PARTS LISTING

**IMPORTANT:** Check all parts are present before beginning work! Contact OFFROAD ANIMAL if something is missing.

## Main Parts – In the Box

Qty	Part Number	Description	Image
1	FB-TFT-N160-21-PR-ASM1	Fortuner 21+ Predator Bar Weldment	
<b>OR</b>			
1	FB-TFT-N160-21-TOR-ASM1	Fortuner 21+ Toro Bar Weldment	
1	FB-TFT-N160-21-PR-ASM2L	Fortuner Chassis Mount Assy	
1	FB-TFT-N160-21-PR-ASM2R	Fortuner Chassis Mount Assy	
1	B-0152L	Hilux Front Mount - Chassis Brace	
1	B-0152R	Hilux Front Mount - Chassis Brace	

1	M-0005	Hilux Mesh - Center Fairlead Support	
1	M-0006L	Hilux Mesh Infill LHS	
1	M-0006L	Hilux Mesh Infill RHS	
1	NPF-COM-SM-ASMO	Number plate flip asm Small	
1	B-0655L	Fortuner 21+ Headlight Infill Panel	
1	B-0655R	Fortuner 21+ Headlight Infill Panel	
1	B-0730L	Fortuner Fog21+ / Indicator Bracket	
1	B-0730R	Fortuner Fog21+ / Indicator Bracket	
1	M-0022L	Predator Indicator / Fog Cover Mesh	

1	M-0022R	Predator Indicator / Fog Cover Mesh	
1	U-0049	Fortuner 2021 Bash Plate	
1	U-0050L	Fortuner 21+ Side Underpanel	
1	U-0050R	Fortuner 21+ Side Underpanel	
1	B-0755	Fortuner 21+ Grille Support Bracket	
1	B-0731	Fortuner 21+ Pan Brace	
1	ADR Compliance Plate Fortuner 21+	FB-TFT-N160-21-PR-ADRCP	
2	LED Autolamps 80AW	LED AUTOLAMPS 80AW LED INDICATOR PARKER COMBO LIGHT, SINGLE BLISTER PACK	
1	LV0590	INDICATOR LOAD REISITOR – TWIN BLISTER PACK	

**(Note Crusade models will have different load resistor supplied)**

**Small Parts – Contained in Small Parts Kit Bag**

Qty	Part Number	Description
44	M6x16 BHCS BLACK ZINC	CREW, BUTTON HEAD CAP, M6X16X1 GR12.9, ISO4042 ZnNi BLACK PASSIVATED FINISH
38	M6 FLAT WASHER BLACK ZINC	M6 Flat Washer, 12x6.1x1, ISO4042 ZnNi BLACK PASSIVATED FINISH
34	M6 FLANGE NUT	Flange Nut, M6x1 G8.8 ZP
2	M8 FLANGE NUT	Flange Nut, M8x1.25 G8.8 ZP
4	M8 FLAT WASHER	M8 FW
6	M8 FLAT WASHER- BLACK ZINC	M8 FLAT WASHER, 16.5x8.4x1.2, ISO4042 ZnNi BLACK PASSIVATED FINISH
4	M8 X 20 BHCS BLACK ZINC	SCREW, BUTTON HEAD CAP, M8X20X1.25, ISO4042 ZnNi BLACK PASSIVATED FINISH
4	M8 X 20 HEX	Bolt Hex, M8X20x1.25, GR8.8 ZP
2	M8 X 16 BHCS BZP	SCREW, BUTTON HEAD CAP, M8X16X1.25 GR12.9, ISO4042 ZnNi BLACK PASSIVATED FINISH
6	M5 FLANGE NUT	Flange Nut, M5x0.8 G8.8 ZP
6	M5 Flat washer	M5 FW
6	M5X15 BHCS	SCREW, BUTTON HEAD CAP, M5X15X0.8 GR12.9 ZP
10	M6CN3MM	CAGE NUT M6x2.6-3.5
12	M10 FLANGE NUT	Flange Nut, M10x1.5 G8.8 ZP
12	M10 FW LHD	WASHER, FLAT M10X28.5X2.5
10	M10 x 30	Bolt Hex, M10X30x[1.5], GR8.8 ZP
2	M10X20 BHCS	SCREW, BUTTON HEAD CAP, M10X20X1.5 GR12.9 ZP
6	M12 FLAT WASHER	M12 FW
12	M12X30	Bolt Hex, M12X30x1.75, GR8.8 ZP
2	M12X30X1.25	Bolt Hex, M12X30x1.25, GR8.8 ZP
2	NP-THL-N80-15- PR	Nut Plate - Hilux Predator
4	M12 FLANGE NUT	Flange Nut, M12x1.75 G8.8 ZP
12	M12 FW LHD	M12 FW Large Heavy Duty
4	M12 Nyloc nut	M12 NYLOC NUT
2	M6x12 BHCS	SCREW, BUTTON HEAD CAP, M6X12X1 GR12.9 ZP

**Toro- Additional Parts**

Qty	Part Number	Description
4	M8 FLAT WASHER- BLACK ZINC	M8 FLAT WASHER, 16.5x8.4x1.2, ISO4042 ZnNi BLACK PASSIVATED FINISH
4	M8 X 20 BHCS BLACK ZINC	SCREW, BUTTON HEAD CAP, M8X20X1.25, ISO4042 ZnNi BLACK PASSIVATED FINISH
2	B-0523	Toro Antenna Bracket - 90 Degree

# TOOLS REQUIRED

The following tools will be required to install the product.

<b>Hand Tools</b>	<b>Power Tools</b>	<b>Workshop Equipment</b>
Metric Socket Set 8-19mm Socket Extension Bar Metric Spanner Set 10-19mm Hex (Allen) Key Set 4-8mm Trim Puller Tool Flat Blade Screwdriver set Phillips Head Screwdriver set Utility Knife	Electric/Air Impact Driver (Optional)  Air Hacksaw, Angle grinder or oscillating multi tool with plastic blade	Panel Stand or Soft Blanket  Automotive Adhesive Sealant.  Glue Removal Solvents

# WORKSHOP SAFETY

It is the responsibility of the installer to always complete works in a safe manner. Make sure the following safety equipment is available and precautions are observed whilst fitting this product.

<p>Hearing Protection</p> 	<p>Always wear ear protection when using power tools.</p>
<p>Eye Protection</p> 	<p>Ensure eye protection is always worn when cutting or drilling.</p>
<p>Manual Handling</p> 	<p>Do not attempt to lift bar assemblies or rock sliders on your own.</p> <p>Always use two people to lift or use mechanical Lifting aid such as hydraulic lifting trolley.</p>
<p>Vehicle Support</p> 	<p>Always ensure vehicle is properly supported when working on it. Do not attempt to fit products whilst suspension work is being carried out. Do not work under a vehicle supported only by a jack.</p>



1. Remove the Radiator shroud by removing the 6x clips securing it to the grille and cross member.
2. Push down on the center of the clips to release then remove with trim tool.

**TOOLS REQUIRED**

Trim Tool

**FASTENERS**

Push Center Clips



3. Remove the 4x 10mm Head screws securing the top of the grille
4. Retain fasteners for re fitment.

**TOOLS REQUIRED**

10mm Socket / Spanner

**FASTENERS**

10mm Head Screws

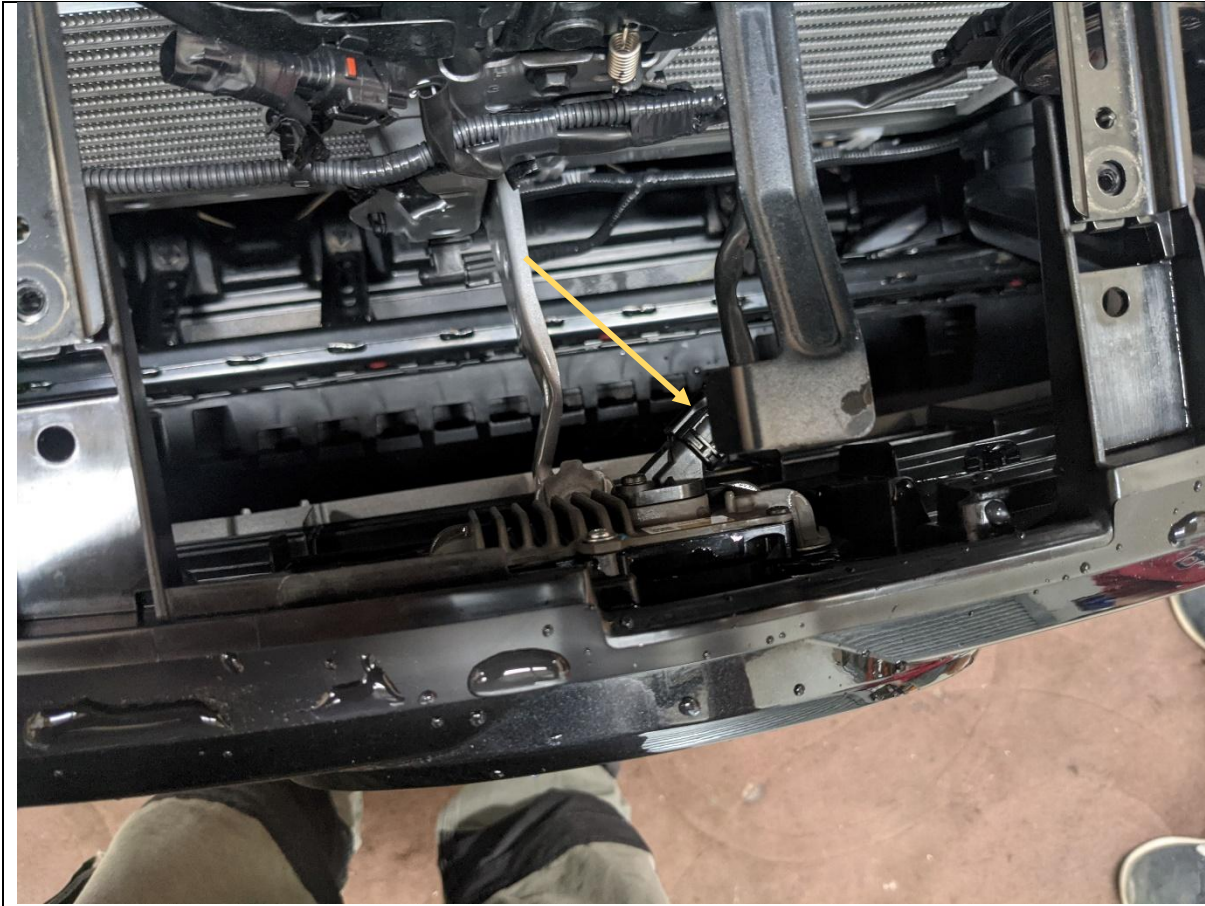

5. Unplug the radar sensor module wiring connector, located on the back of the Toyota Badge / sensor.

**TOOLS REQUIRED**

**FASTENERS**

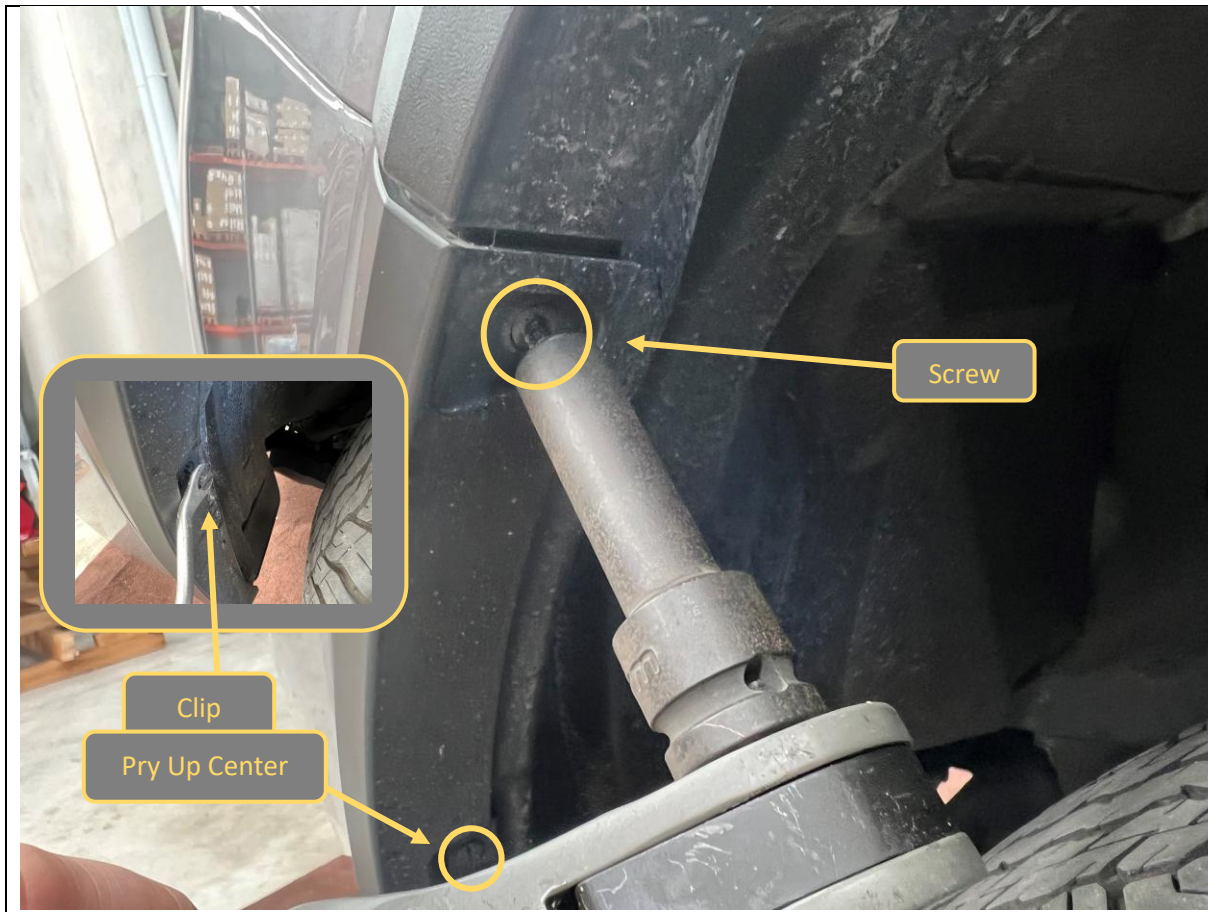

6. Remove the small screw and clip securing the bumper to the inner wheel arch liner.
7. Clip is a center release type. Pry up the center section to unlock then remove.

**TOOLS REQUIRED**

8mm Socket  
Trim Tool

**FASTENERS**

Factory Clip and Screw



8. Remove the 4x 10mm head Screws securing bottom corner of bumper to inner wheel arch liner.
9. Complete on both sides of Vehicle

**TOOLS REQUIRED**

10mm Socket / Spanner

**FASTENERS**

Factory Screws



10. Remove the 3x 10mm head Screws securing bottom center section of bumper to inner wheel arch liner.

**TOOLS REQUIRED**

10mm Socket / Spanner

**FASTENERS**

Factory Screws



11. Remove the chrome headlight trim panels by carefully prying then pulling in a forward direction to release clips holding.

**TOOLS REQUIRED**

**FASTENERS**



12. Remove the 2x 10mm Head/Phillips screws securing the bumper to crossmember.  
  
These screws are located on the edge near the headlights behind chrome trim.
13. Remove clips and central screw behind grille securing to center crossmember.

**TOOLS REQUIRED**

10mm Spanner  
Trim Tool

**FASTENERS**

Factory screws  
Factory clips



14. Remove the bumper. Start by pulling from the outside where the bumper meets the wheel arch and work towards the center from both sides.

**TOOLS REQUIRED**

**FASTENERS**



15. With assistance once the bumper is loose, unplug and release the parking sensor, indicator/parker lamp and fog light harnesses.
16. It is easiest to remove the sensor from the bumper by releasing the clips on back side then pushing sensor through the bumper, leaving it hanging on the cable.
17. This needs to be done on both sides of the vehicle.

**TOOLS REQUIRED**

**FASTENERS**



- 18. Once bumper is removed set aside on soft non marking surface or panel stand.
- 19. Release the bumper from the grille by releasing all the clips along the bottom of grille with a trim tool.

**TOOLS REQUIRED**

Trim Tool

**FASTENERS**



20. Remove the front bumper support plastic fasteners using trim tool and Phillips screwdriver to pry whilst loosening as shown.
21. Remove the forward bolt using 10mm socket.
22. Remove the bumper support using a trim tool.
23. Replace the forward bolt to re-secure the headlight to the wing.
24. Complete on both sides of the vehicle

**TOOLS REQUIRED**

Trim Tool  
Phillips Screwdriver  
10mm socket

**FASTENERS**

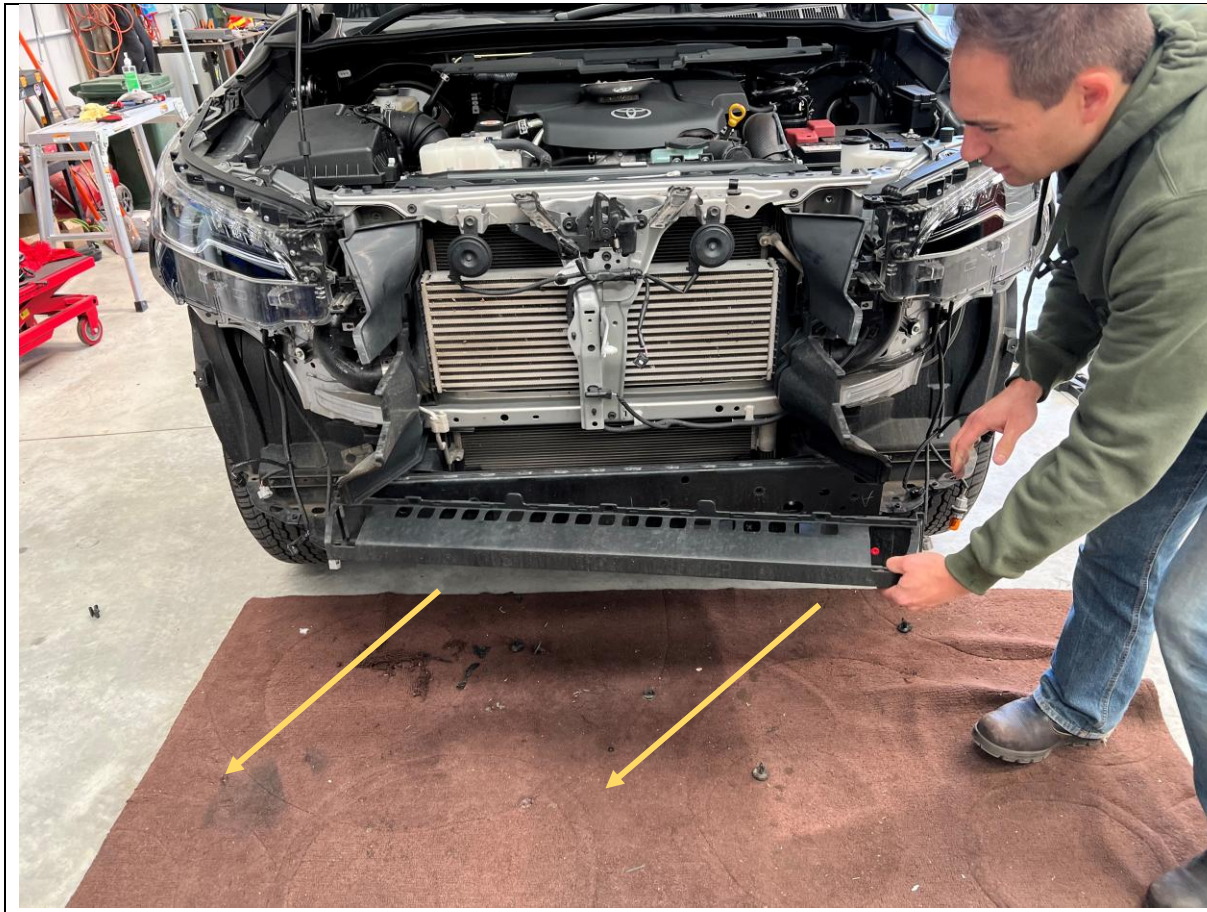

25. Remove the plastic cover from the impact beam by strongly pulling in the direction shown to release it from the clips

**TOOLS REQUIRED**

**FASTENERS**

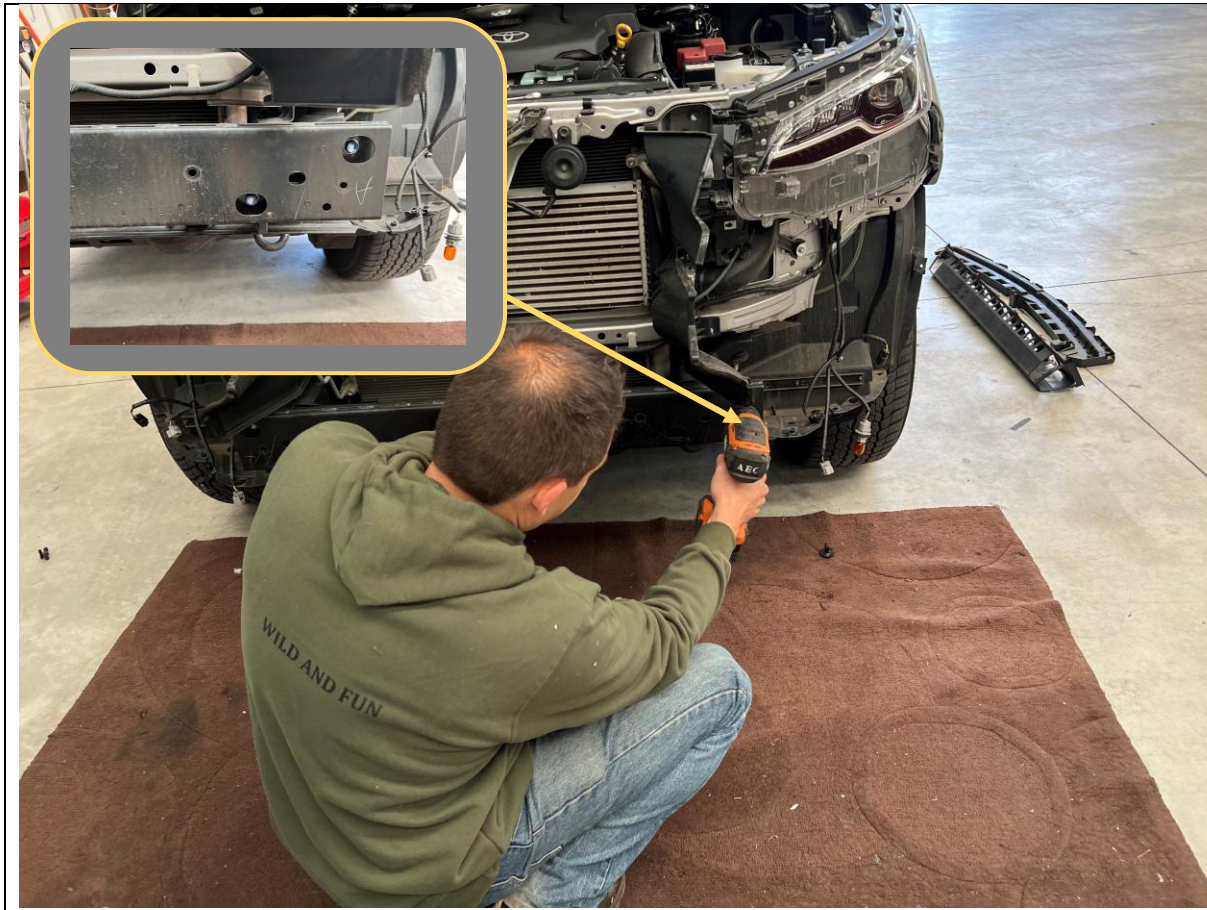

- 26. Remove the impact beam by removing the 4x factory flange bolts securing it to the chassis rail
- 27. Release plastic clips behind the impact beam in the air guides.

**TOOLS REQUIRED**

15mm Socket  
Trim Tool

**FASTENERS**

Factory flange bolts  
Retain



28. Remove the lower splashguard by removing the 10mm head bolts securing to vehicle.

**TOOLS REQUIRED**

10mm socket / spanner

**FASTENERS**



- 29. Vehicle chassis rails should now be totally exposed as shown.
- 30. For light colored vehicles it is a good idea to paint the exposed panels beneath the headlight black, to ensure a neat appearance once bar is fitted.

**TOOLS REQUIRED**

**FASTENERS**



<ol style="list-style-type: none"> <li>31. Remove air guides from vehicle by releasing the 3x clips holding it to the chassis.</li> <li>32. Mark air guides as shown in the above image. Trim along marked line using sharp utility knife or oscillating multi tool.</li> <li>33. Re fit top half of air guide to vehicle.</li> </ol>	<p><b>TOOLS REQUIRED</b></p> <p>Trim tool Paint Marker</p> <p>Utility knife or Oscillating multi tool with plastic cutting blade</p>
	<p><b>FASTENERS</b></p>



34. Take the chassis brace and fit loosely to the threaded M12 fine pitch insert in chassis, using M12x30x1.25 Bolt and flat washer.
35. Insert the Nut Plate into the chassis rail through the opening on the front of the chassis.
36. Secure the nut plate with M12x30 standard pitch bolts and flat washers through the holes shown. Leave finger tight at this stage.
37. Repeat for other side of vehicle.

**TOOLS REQUIRED**

**FASTENERS**

1x M12x30x1.25p Bolt  
2x M12x30x1.75p Bolt  
3x M12 Flat washer

Per side

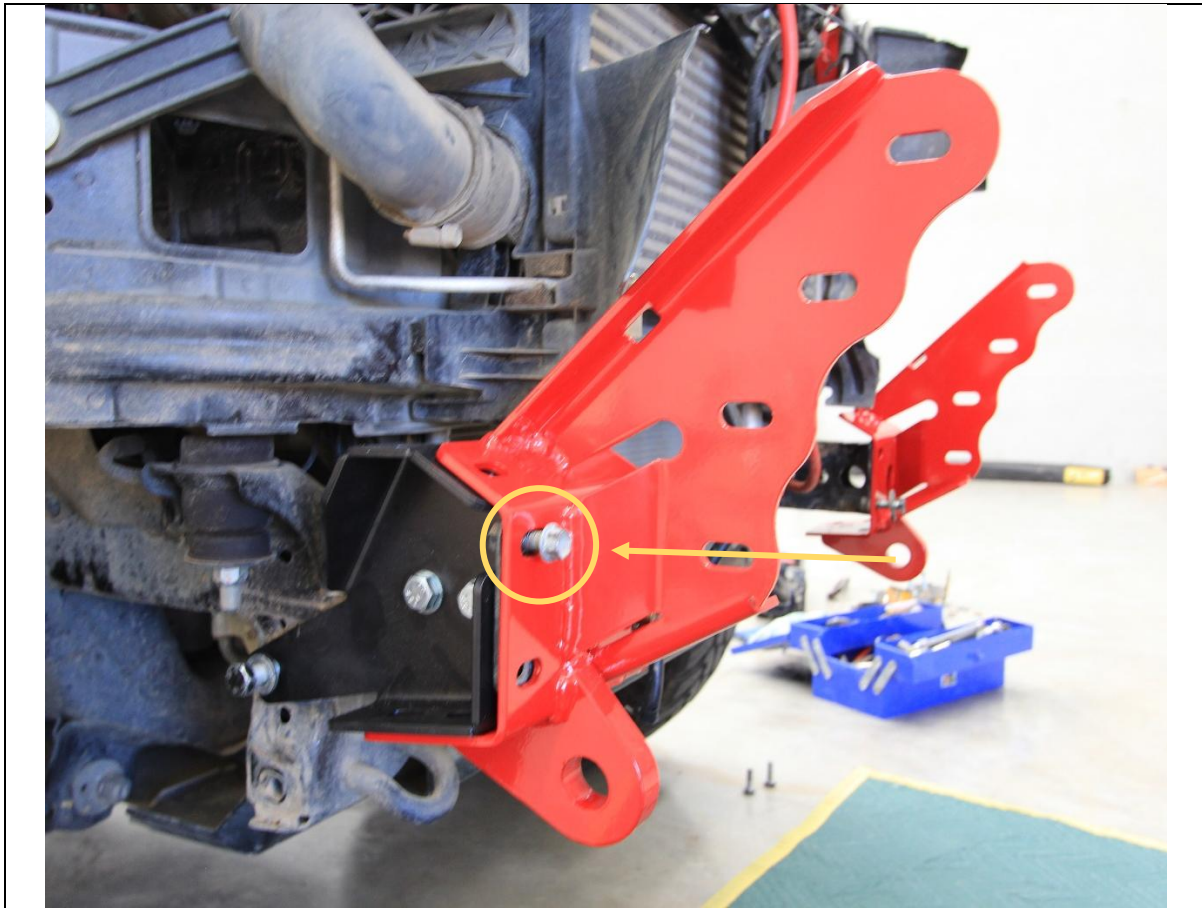

- 38. Fit the impact assembly to the end of the chassis rail.
- 39. Secure finger tight with the original M10 bolts in the threaded inserts in chassis.
- 40. Repeat for other side of vehicle

**TOOLS REQUIRED**

**FASTENERS**

2x Factory M10 flange bolt

Per side

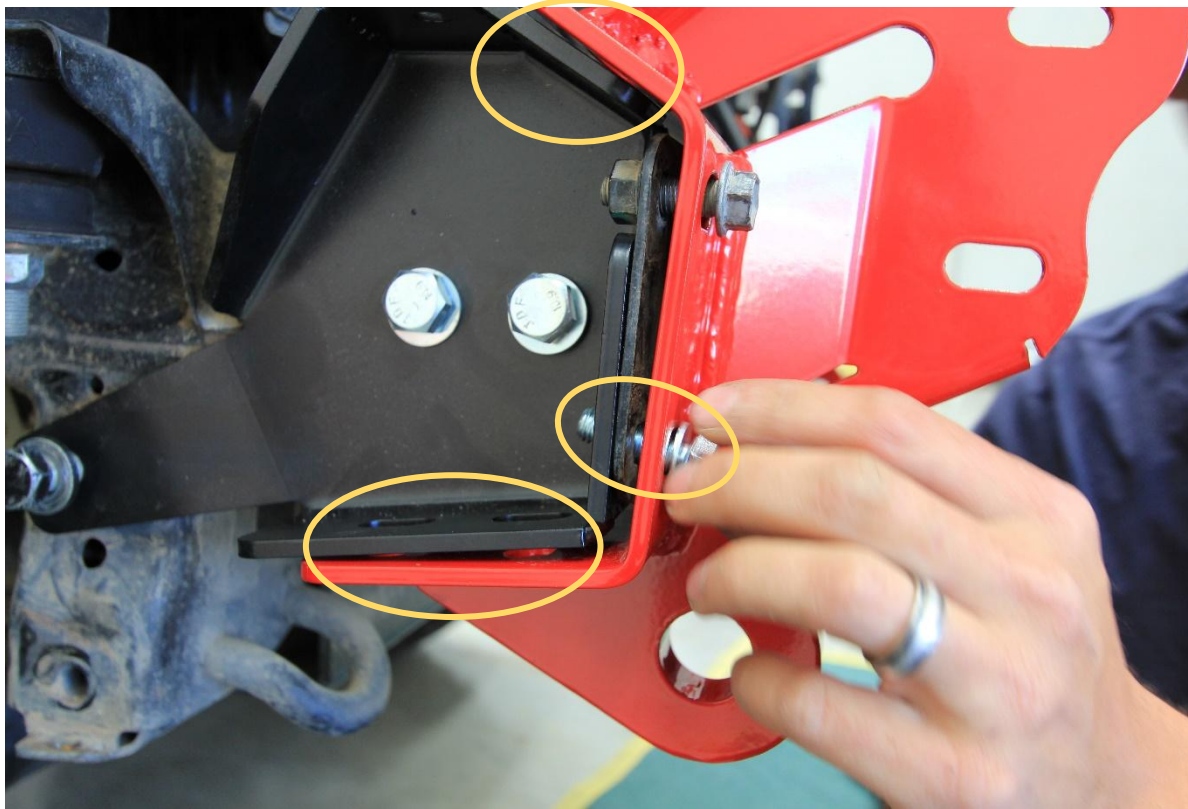

- 41. Fit remaining bolts to the impact assembly. 2x M10x30 Bolts, 2x Flat washers and 2x flange nuts to front face.
- 42. Fit 2x M10x30 Bolts, 2x Flat washers and 2x flange nuts to Bottom face.
- 43. Fit 1x M10x30 Bolt, 1x Flat washer and 1x flange nut to Top face.

**TOOLS REQUIRED**

**FASTENERS**

5x M10x30 Bolt  
5x M10 Flat washer  
5x M10 Flange nut

Per side

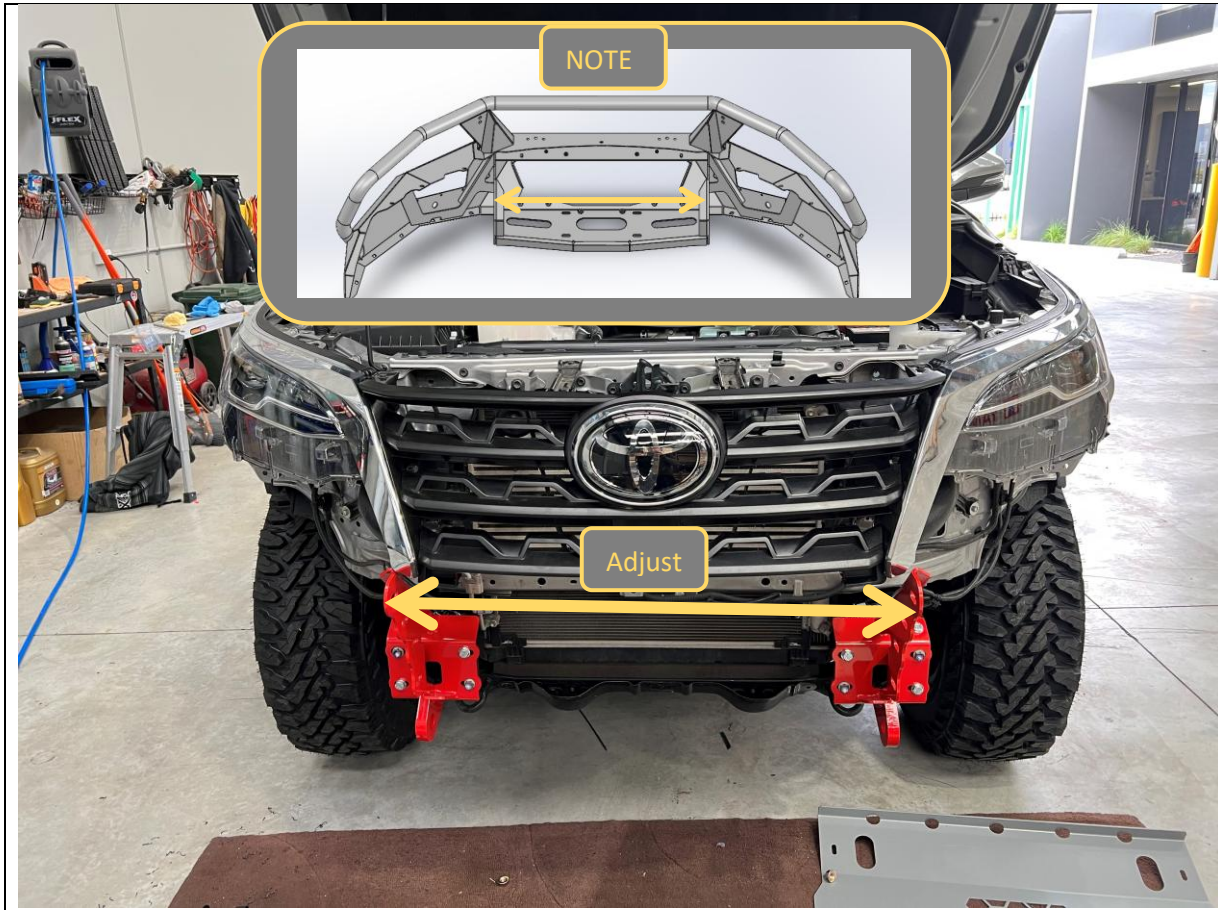

<p>44. Measure the distance between the outside faces of the uprights on the bar. Note this distance</p> <p>Bar uprights _____ mm</p>	<p><b>TOOLS REQUIRED</b></p> <p>Tape measure 16mm Spanner 16mm Socket</p>
<p>45. Adjust the distance between the impact assemblies to be approx. 1-2mm greater than the upright distance on the bar.</p> <p>46. Tighten bolts on the impact assemblies and re-check distance. Loosen and adjust as required until the distance between mounts when mounts are tight is correct.</p>	<p><b>FASTENERS</b></p>



47. Remove the 3x Screws securing the fog lights to the bumper, then remove the fog light from the bumper.

**TOOLS REQUIRED**

Screwdriver

**FASTENERS**

Factory Screws



48. Remove the gloss plastic trim panel from the main bumper assembly by releasing clips securing, to gain better access to parking sensor housing.

**TOOLS REQUIRED**

Trim Tool

**FASTENERS**

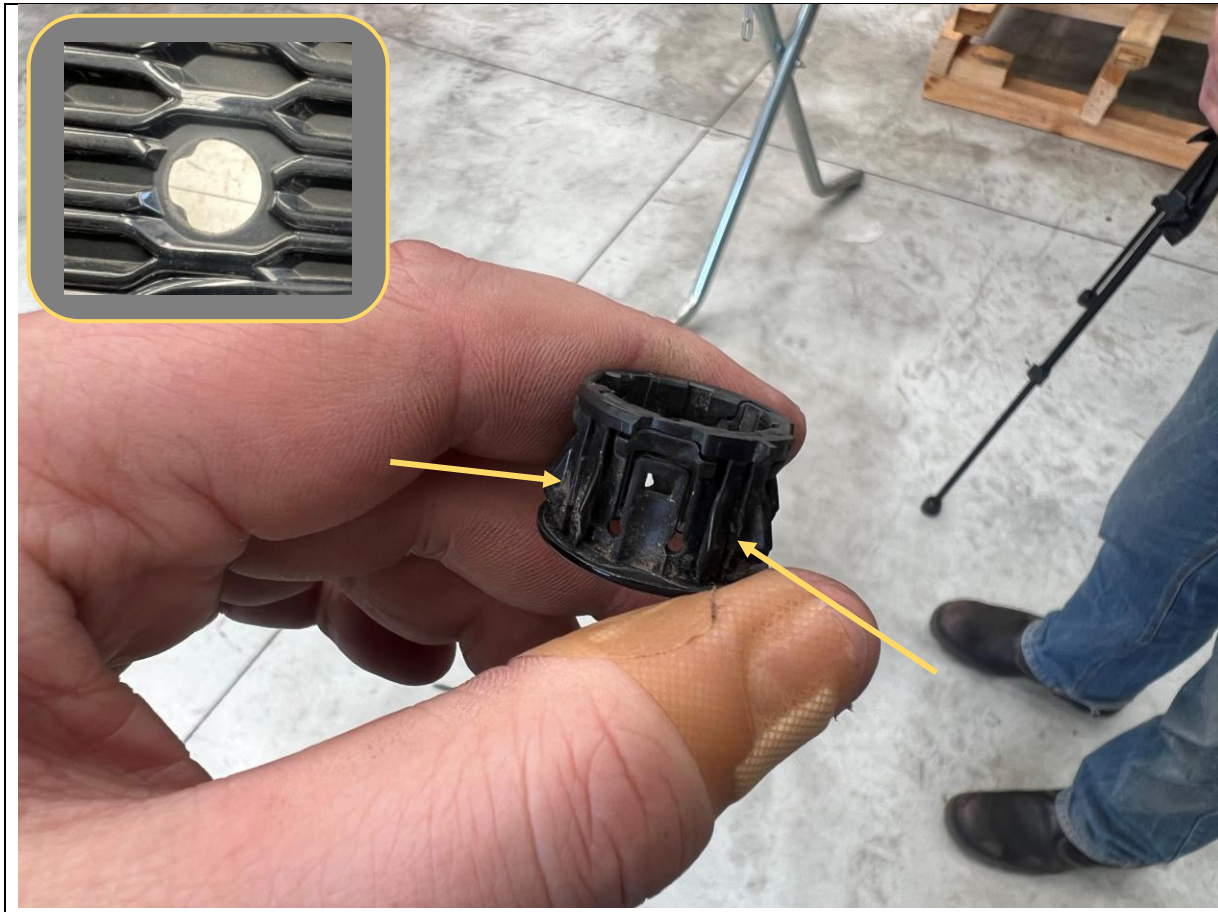

<p>49. Remove the sensor housing from the plastic trim panel.</p> <p>50. Compress the tabs on the side of the sensor housing whilst pushing from the back side toward the front of the trim panel.</p>	<p><b>TOOLS REQUIRED</b></p> <p>Trim Tool</p>
<p>51. Re-fit sensor housings to holes in bull bar, by simply pushing into sensor holes from the front side of the bar until they click into place.</p>	<p><b>FASTENERS</b></p>

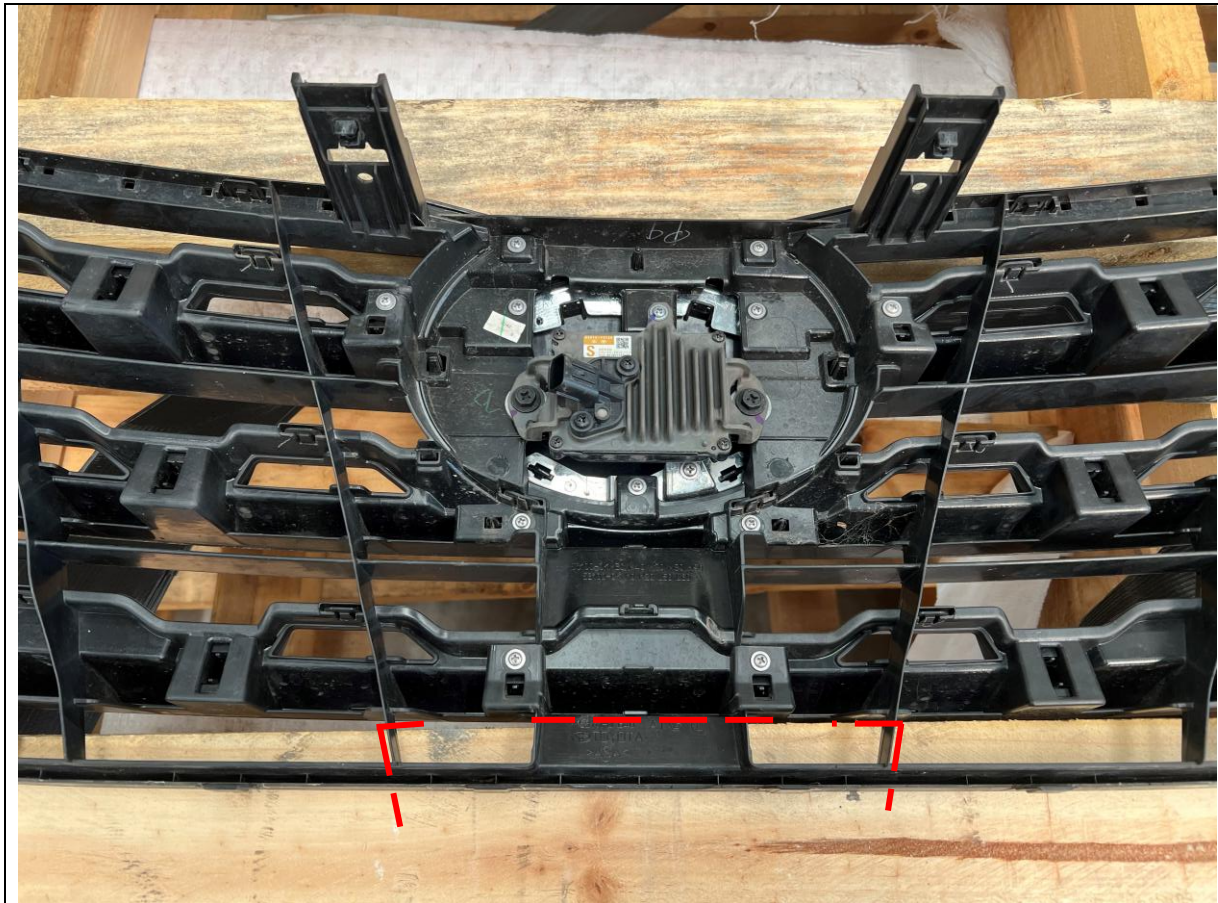

- 52. If fitting a winch with an integrated control pack, a small grille trim will be required. Winches with remote control packs, or fitments with no winch installed can skip this step.
- 53. The Mark out the grille cut as denoted by lines in image. Ensure it is symmetric.
- 54. Using angle grinder or air hacksaw, cut along edge of the tape.

**TOOLS REQUIRED**

Masking Tape

**FASTENERS**

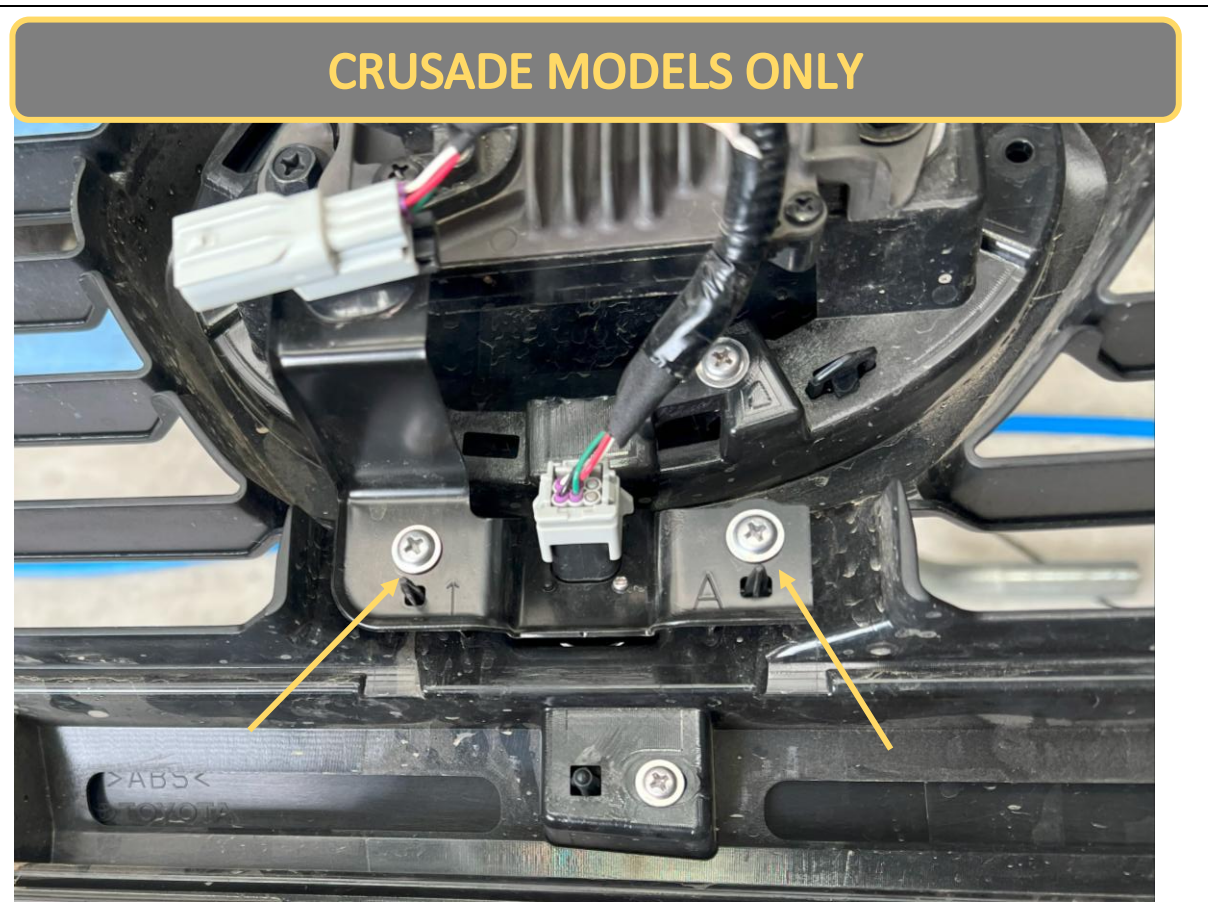

<p>55. If your vehicle is fitted with a front camera you can choose to relocate the front camera to the fairlead mesh panel. This will improve the camera field of view.</p> <p>56. If relocating the camera remove module from the grille with 2x Phillips head screws.</p> <p>57. Unclip wiring harness from bracket but leave the camera attached to the bracket.</p>	<p><b>TOOLS REQUIRED</b></p> <p>Phillips head screwdriver Trim tool</p>
	<p><b>FASTENERS</b></p> <p>Factory Screws</p> <p>Retain</p>

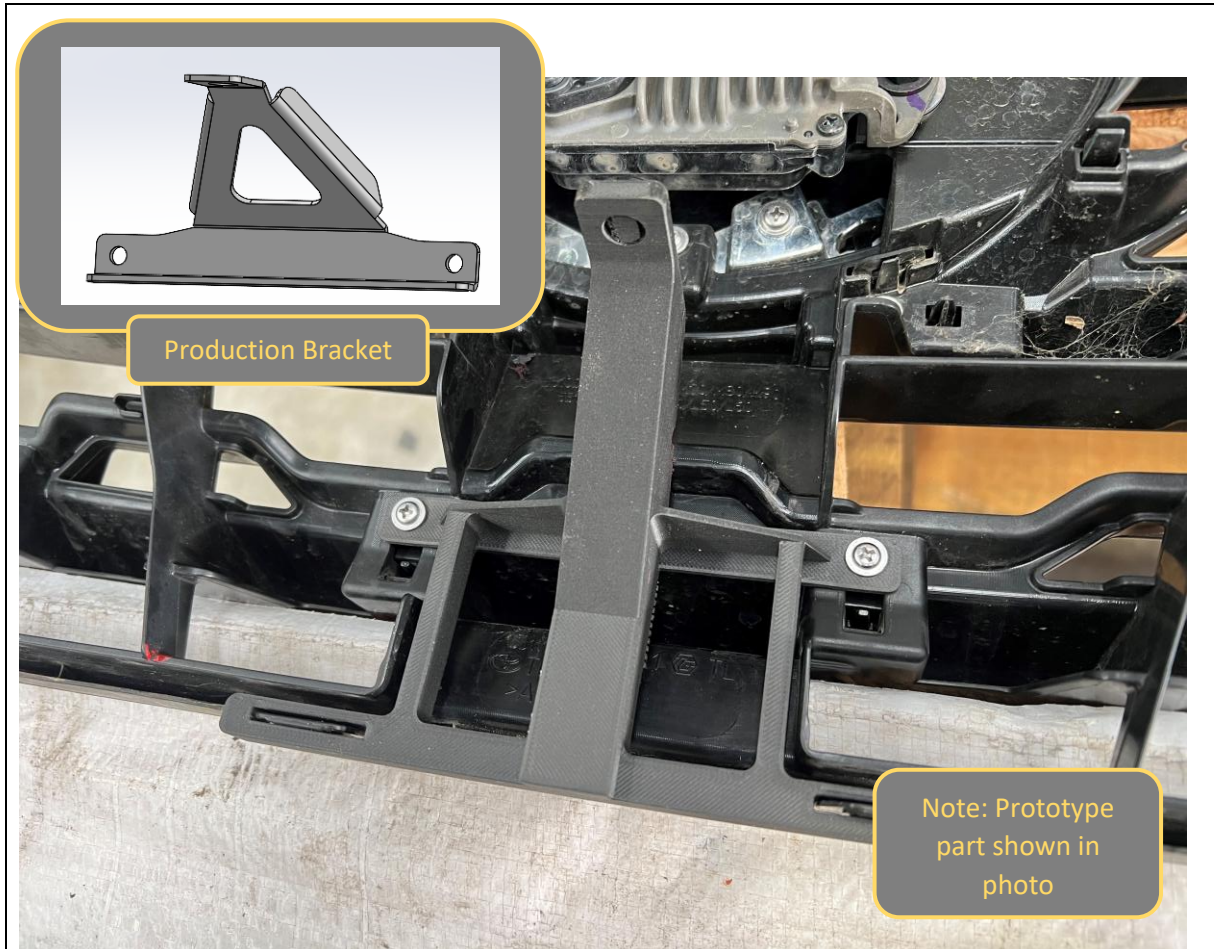

58. Fit the bottom grille support bracket to the middle of the top section of the grille, under the adaptive cruise radar sensor.
59. Remove the existing Philips head screw, then re fit with bracket in place.

**TOOLS REQUIRED**

Phillips head screwdriver

**FASTENERS**

Factory screws

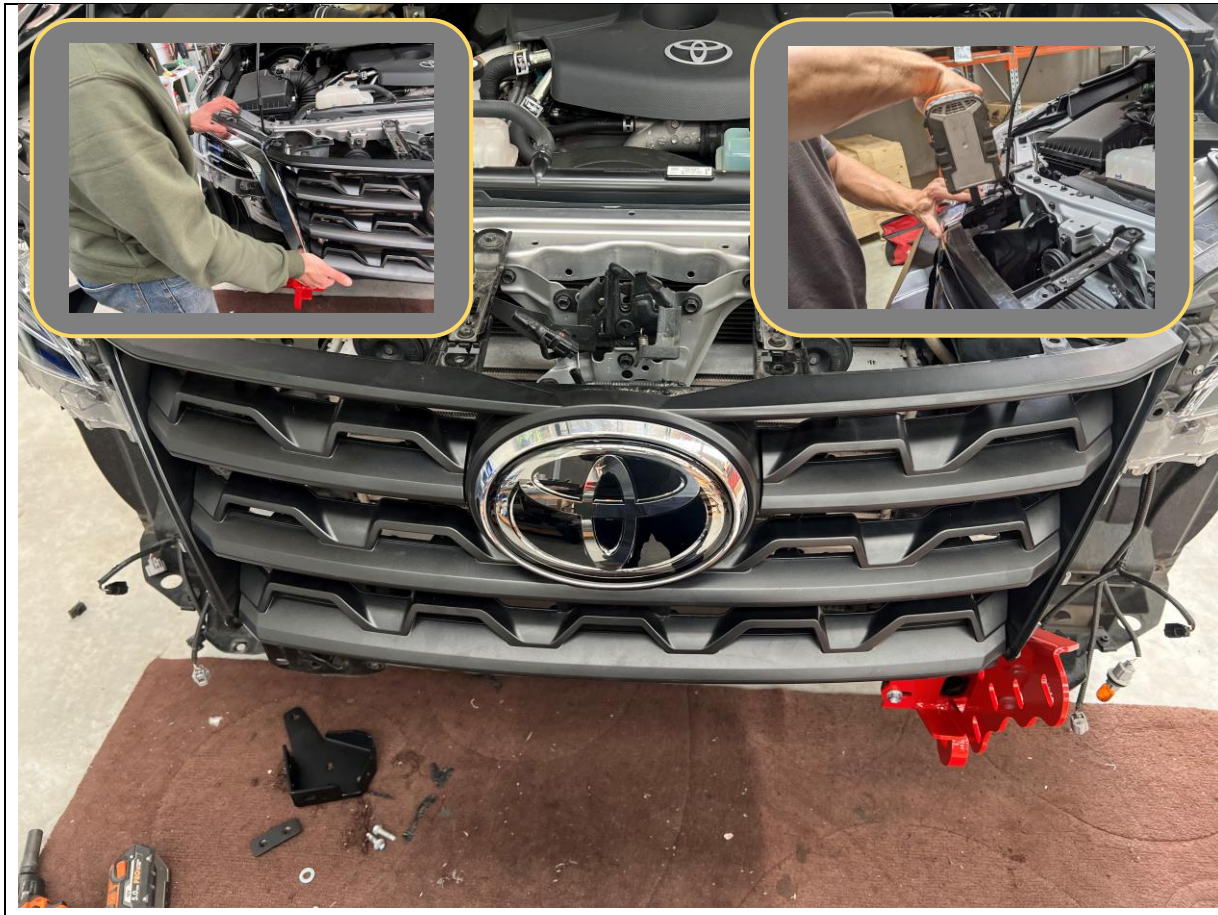

<p>60. Re-fit the grille to the vehicle.</p> <p>61. Secure top of grille using original 10mm fasteners.</p> <p>62. Secure the grille support bracket to the vehicle body using factory screw removed during bumper removal.</p>	<p><b>TOOLS REQUIRED</b></p> <p>10mm Socket Phillips head screwdriver</p>
<p>63. Re fit the chrome trims to the grille / headlight.</p>	<p><b>FASTENERS</b></p> <p>Factory screws</p>



- 64. If fitting a light bar and/or driving lights to the center section of the bar, do so at this stage, before fitting the bar to the car.
- 65. Use hardware provided with the Lights to fit to the bar.
- 66. Fit pan brace to back side of light bar opening using M6x16 Black fastener on top and M6x12 Fastener on bottom, with flat washers and flange nuts.

**TOOLS REQUIRED**

**FASTENERS**

- 1xM6x12 Button Head Screw
- 1xM6x16 Black Button Head Screw
- 2x M6 Washer
- 2x M6 Flange Nuts

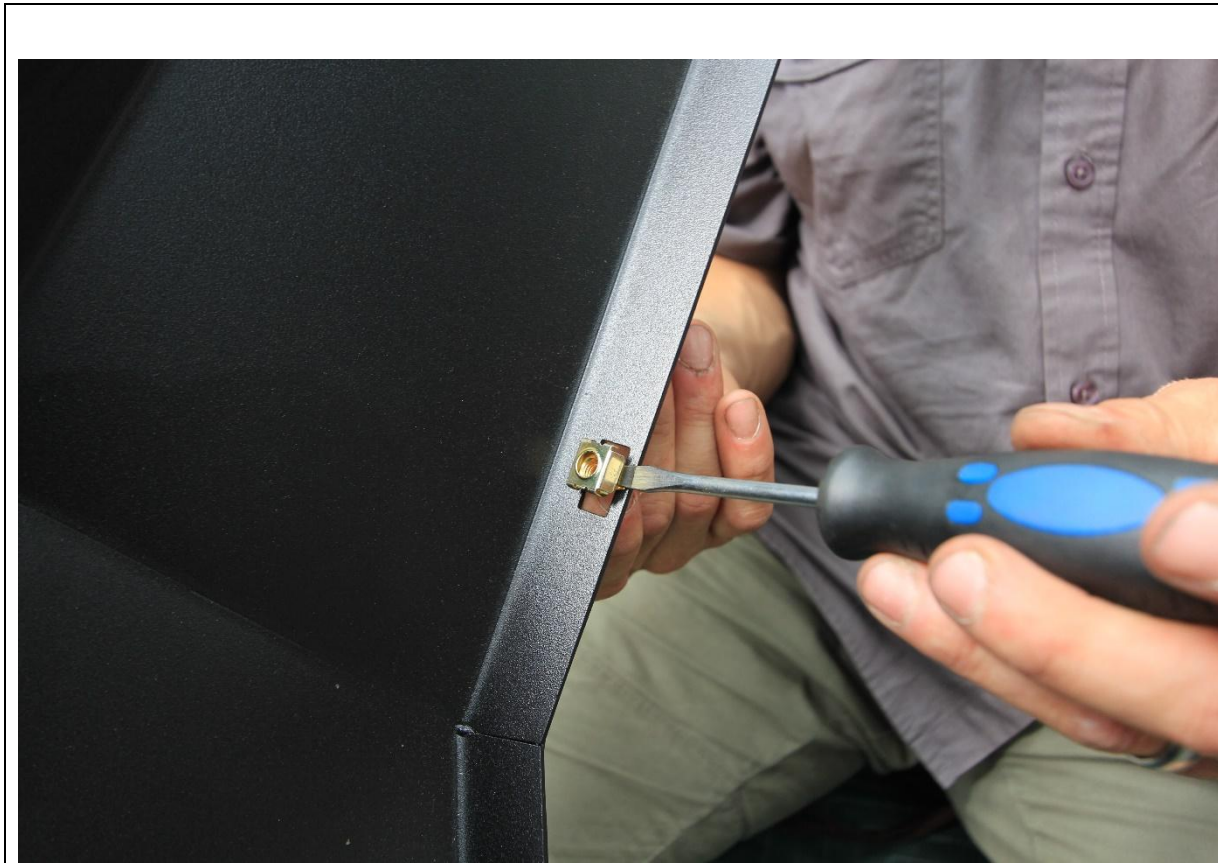

67. Insert cage nuts to square slots in bottom of wings. Seat cage nut against one edge of slot then push other edge in with flat bladed screwdriver.

**TOOLS REQUIRED**

Flat bladed screwdriver

**FASTENERS**

5x M6 Cage Nuts

Per side



68. Fit the headlight infill panels to the top of the bar, using supplied M5 Hardware. Leave finger tight at this stage.

Fit with flange nut on top, to allow tightening of bolts from below once bar fitted to the vehicle.

**TOOLS REQUIRED**

**FASTENERS**

- 6x M5x12 Button Head Bolt
- 6x M5 Washer
- 6x M5 Flange Nuts

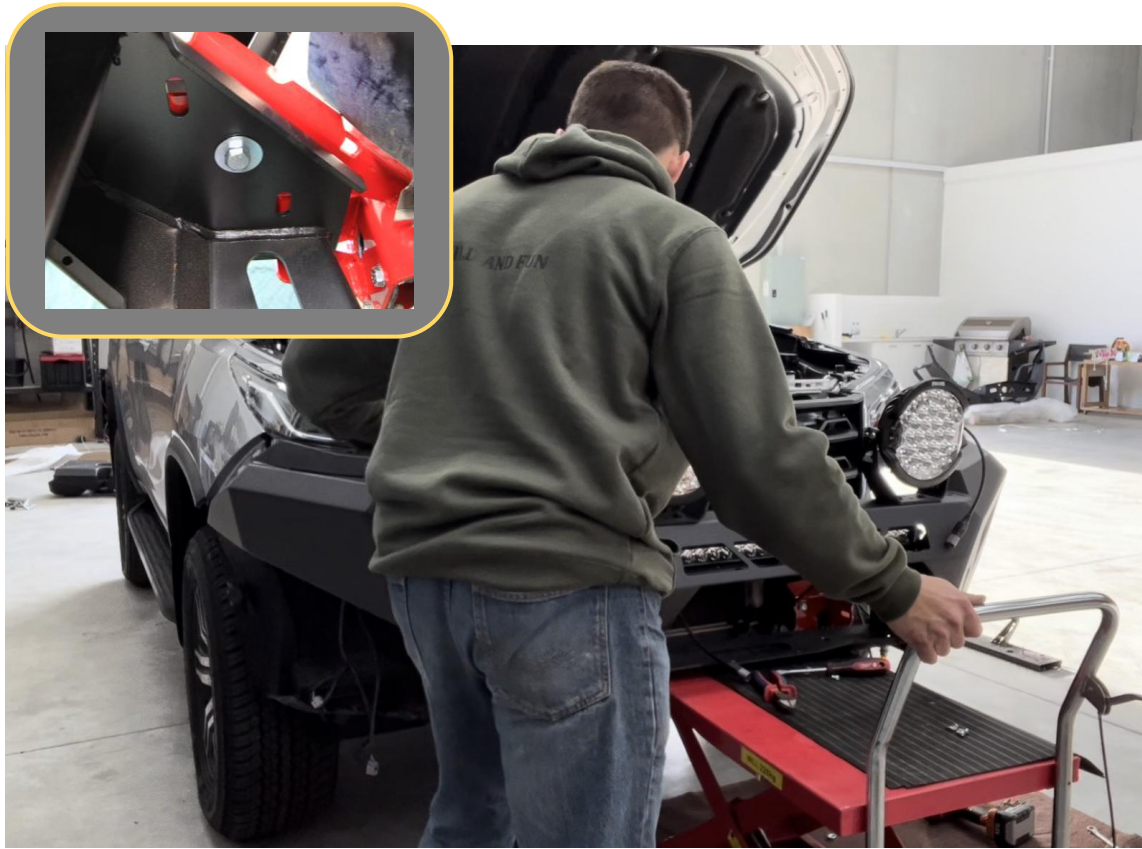

- 69. With assistance, from either another person or mechanical lifting aid such as a lift trolley, offer the bar up to the mounts.
- 70. Secure the bar to the mounts using 2x M12x30 Bolt, 2x M12 Heavy Duty flat washers and 2x M12 Flange Nut per side
- 71. Loosely fit the other 2x M12x30s Bolt, 4x M12 Heavy Duty flat washers and 2xM12 Nyloc Nuts per side.

**TOOLS REQUIRED**

Lifting trolley

**FASTENERS**

8x M12x30 Bolt  
12x M12 HD Washer  
4x M12 Nyloc Nuts  
4x M12 Flange Nuts

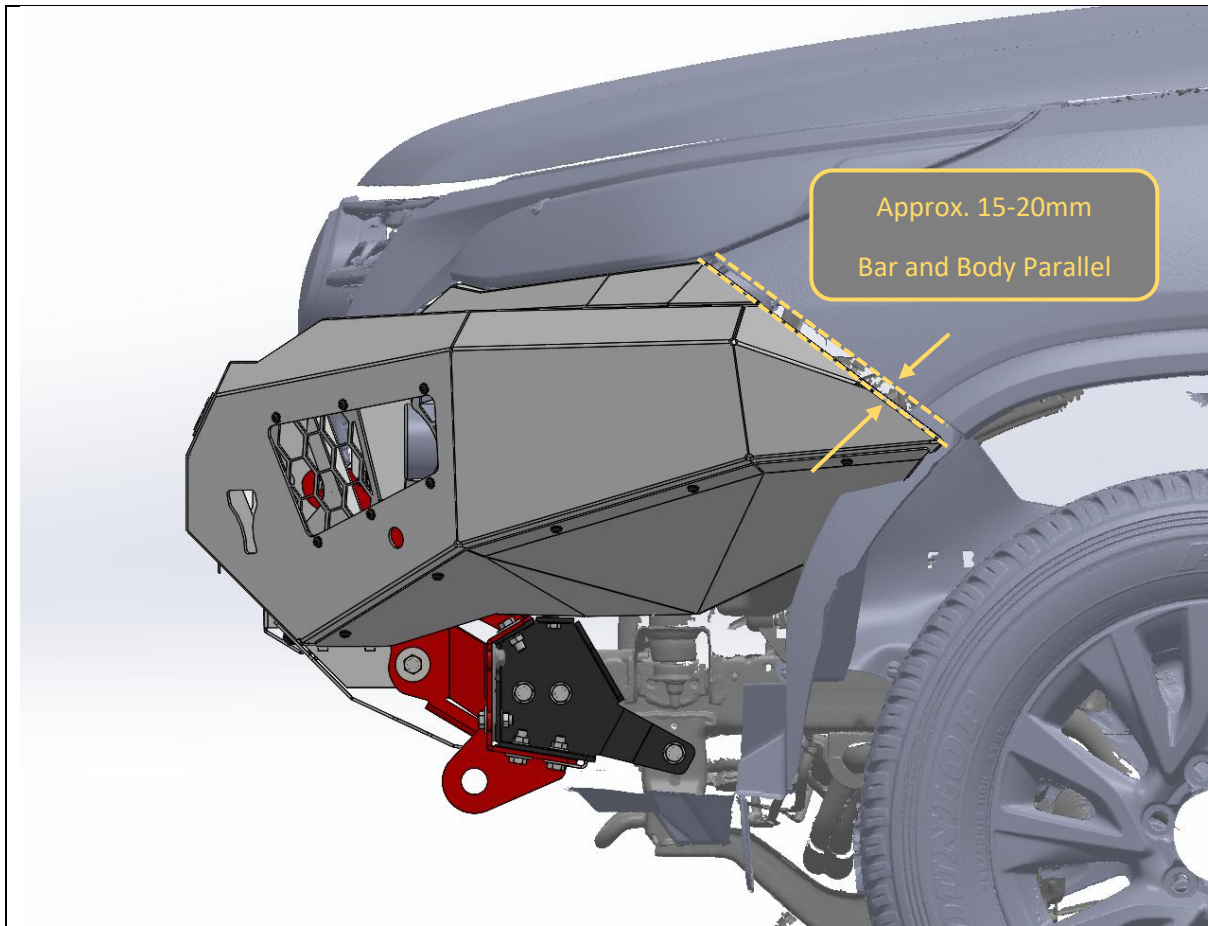

72. Align the bar with the body. Aim for 15-20mm clearance between the wing and body.

**IMPORTANT:** It is the installer's responsibility to ensure clearances are set so that no part of the bar touches the vehicle. Remember that body is rubber mounted and will move relative to bar in use.

73. With assistance, Hold the bar in position and tighten all the Bar to mount bolts, using 19mm socket and spanner.

An Electric Impact wrench makes this process much easier.

**TOOLS REQUIRED**

19mm socket  
19mm spanner

**FASTENERS**



- 74. Align the headlight infill panels, ensure that they sit **IN FRONT** of the headlight and have as even a gap as possible.
- 75. Once in position, tighten from underneath using a 3mm Hex key.

**TOOLS REQUIRED**

3mm Hex Key

**FASTENERS**



- 76. If fitting a winch to the bar, do so at this stage. Follow the winch manufacturer’s instructions.
- 77. The winch mounts feet down and is inserted through the front opening of the bar.

**TOOLS REQUIRED**

Refer to winch Instructions

**FASTENERS**

Refer to winch Instructions



- 78. If fitting winch, attach fairlead to center mesh panel using bolts supplied in winch fitting kit. Ensure winch rope is fed through fairlead.
- 79. Fit number plate flip to mesh panel using M6x20 Hex bolt, Flat washer and flange nut, supplied in number plate flip kit.
- 80. If relocating the camera module, fit to the center mesh panel, using the original bracket, and supplied M6x16 button head screws, flat washers, and flange nuts.

**TOOLS REQUIRED**

10mm Socket  
4mm hex key

**FASTENERS**

2x M6x20 Hex Bolt  
4x M6 Flat washer  
4x M6 Flange Nut  
2x M6x16 Black Button Head



- 81. Fit Mesh panel to the bar. Secure with 2x M8x16 Black Button Head Screws and M8 black washers to the threaded inserts at top and 2x M8x20 hex bolts and M8 Flat washer to the threaded inserts at Bottom.
- 82. If fitted re-connect camera module wiring.

**TOOLS REQUIRED**

5mm Hex Key  
10mm spanner

**FASTENERS**

2x M8x16 Button Head  
2x M8 Black Flat Washer  
2x M8x20 hex bolt  
2x M8 Flat Washer



- 83. Fit the side mesh panel to the bar, using only the top point at this stage. Secure with 1x M6x16 Black Button head, bolt and Black M6 Flat washer into threaded insert.
- 84. Repeat for other side of vehicle.
- 85. Fit Number Plate to number plate flip, using M5 fasteners supplied with number plate flip

**TOOLS REQUIRED**

4mm Hex Key

**FASTENERS**

2x M6x16 Button Head  
2x M6 Black Flat Washer

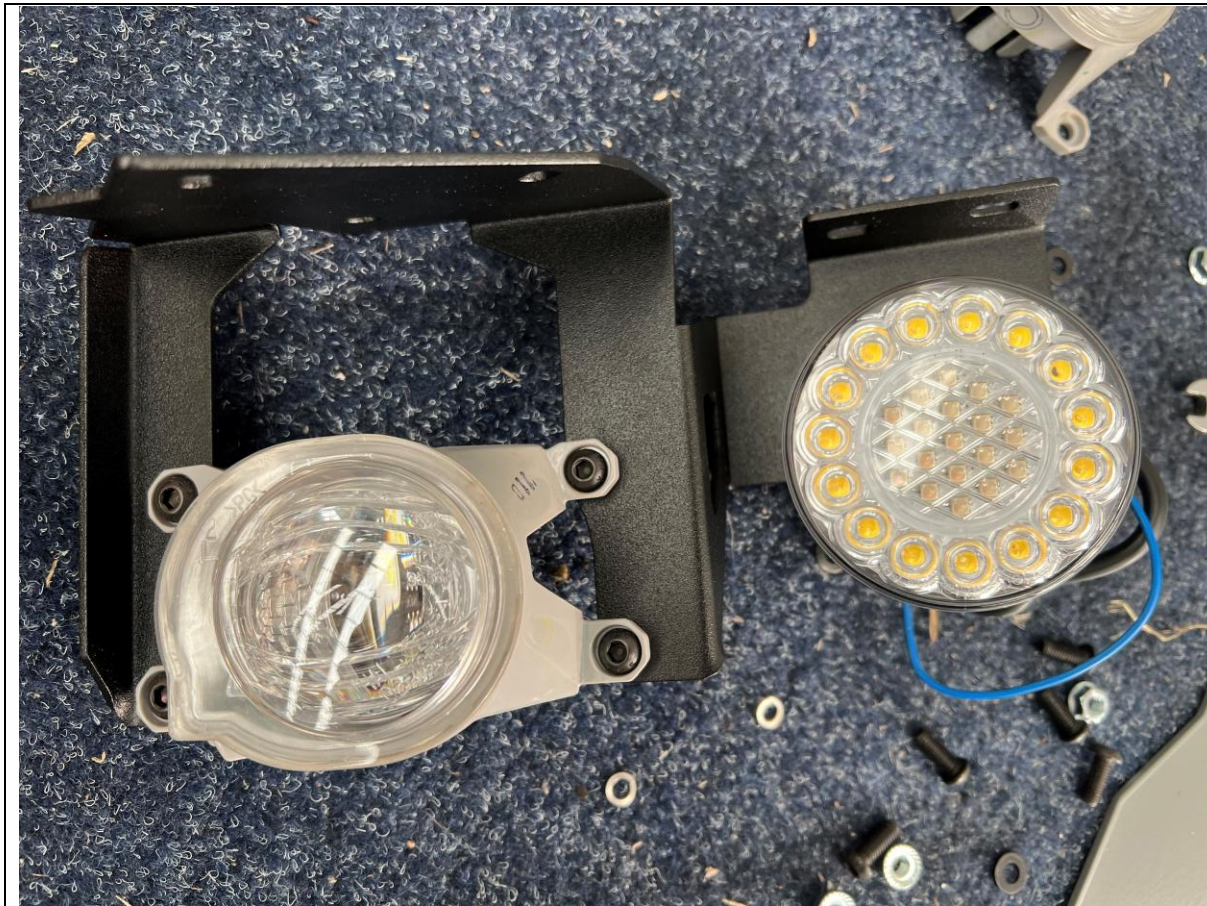

- 86. Re-fit the fog lamps to the supplied fog/indicator lamp brackets using the M6x16 black button head bolts and Flange nuts provided.
- 87. Fit the supplied indicator/parker combo lamp to the bracket using fasteners supplied with the combo lamp.

**TOOLS REQUIRED**

4mm Hex Key  
10mm Spanner

**FASTENERS**

4x M6x16mm black button head  
4x M6 Flange Nuts

Per side



88. Fit the fog/indicator lamp brackets, to the light mesh panels using 4x M6x16 Button head bolts. The bracket should sit on TOP of the light mesh as shown.

89. Repeat for both sides of vehicle.

**TOOLS REQUIRED**

4mm Hex Key  
10mm Spanner

**FASTENERS**

4x M6x16mm Button head bolts  
4x M6 Flat Washer  
4x M6 Flange Nuts

Per side



<p>90. Fit light mesh panels to the bar. Position the panel from underneath the bar and align with the mounting holes in the wing. Secure with 6x M6x16mm Button head bolts and M6 Flange Nuts.</p> <p>91. Repeat for other side of vehicle.</p> <p>92. Reconnect fog lights, or additional driving lights, depending on what was fitted.</p>	<p><b>TOOLS REQUIRED</b></p> <p>4mm Hex Key 10mm Spanner</p>
	<p><b>FASTENERS</b></p> <p>6x M6x16mm Button head bolt 6xM6 Black Washer 6x M6 Flange Nut</p> <p>Per side</p>

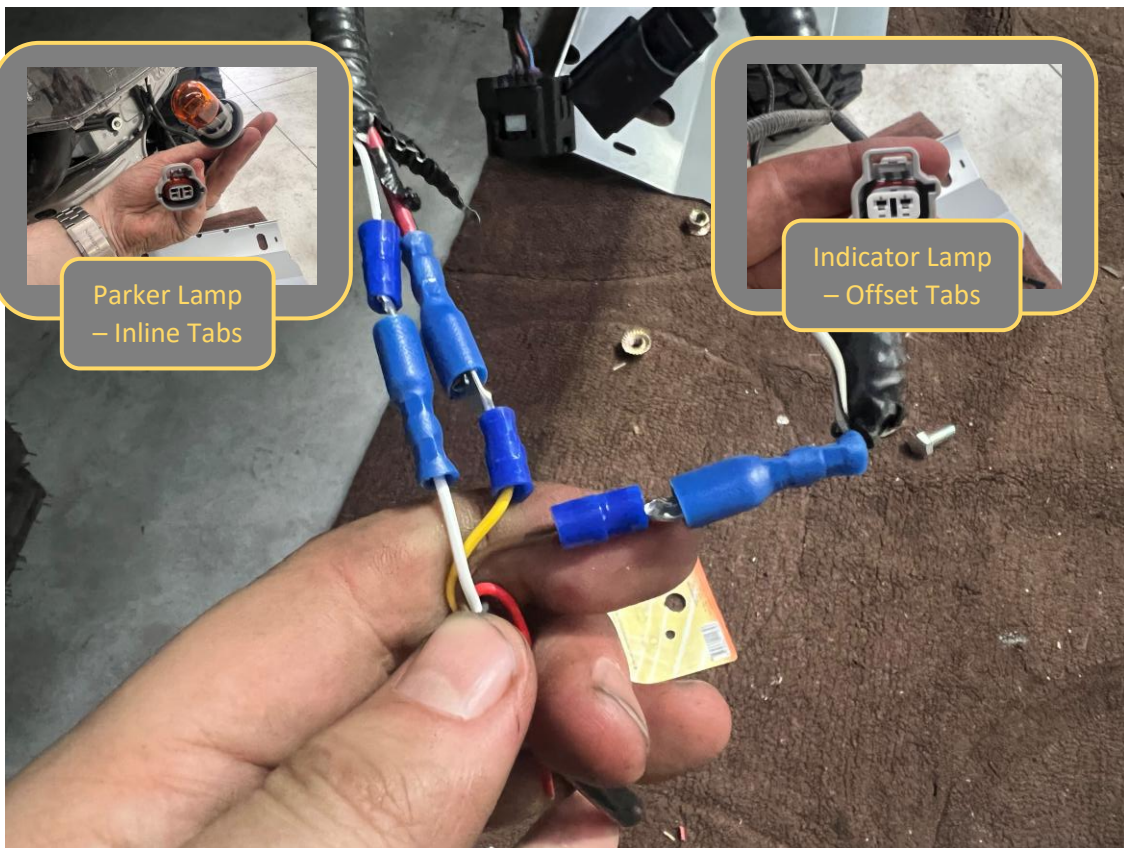

93. Complete wiring for indicator and parker lamp. First identify the indicator and parker lamp circuits by plug type and note down colors for both circuits in the table below.
94. Once noted cut off OE connectors for indicator and parker circuits.
95. Using Crimp connectors or soldering, connect the following wires.

Purpose	Lamp Color	Car Color LHS	Car Color RHS
Indicator +ve	Yellow		
Parker +ve	Brown		
Earth	White		

NOTE: Lamp colors correct at time of printing. Double Check Legend on lamp packaging to ensure lamp colors are not changed by lamp manufacturer.

**TOOLS REQUIRED**

- Crimp connectors
- Crimping tool
- Wire strippers
- Side Cutters

**FASTENERS**

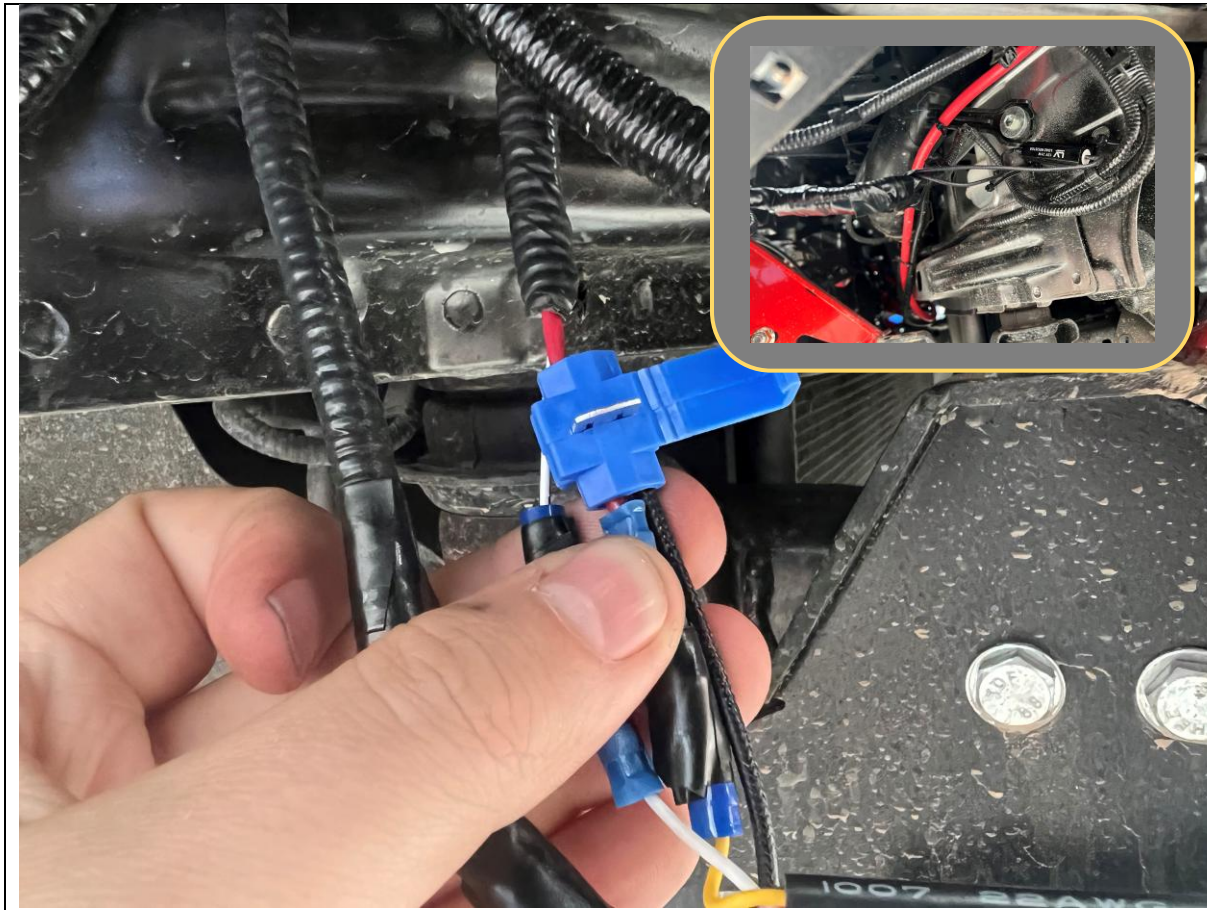

- 96. Check operation of indicators and parker lamps.
- 97. If indicators are blinking too fast, fit supplied Load resistors in parallel to the indicator circuit.
- 98. Use the insulation displacement connectors supplied to connect the resistors. Insert both wires (resistor wire and vehicle wire) in the connector then crimp metal tang with pliers. Close plastic clip once crimped.
- 99. Tape up all connections and neatly tie resistor to vehicle body with cable ties.

**TOOLS REQUIRED**

Electrical tape

**FASTENERS**

Cable ties

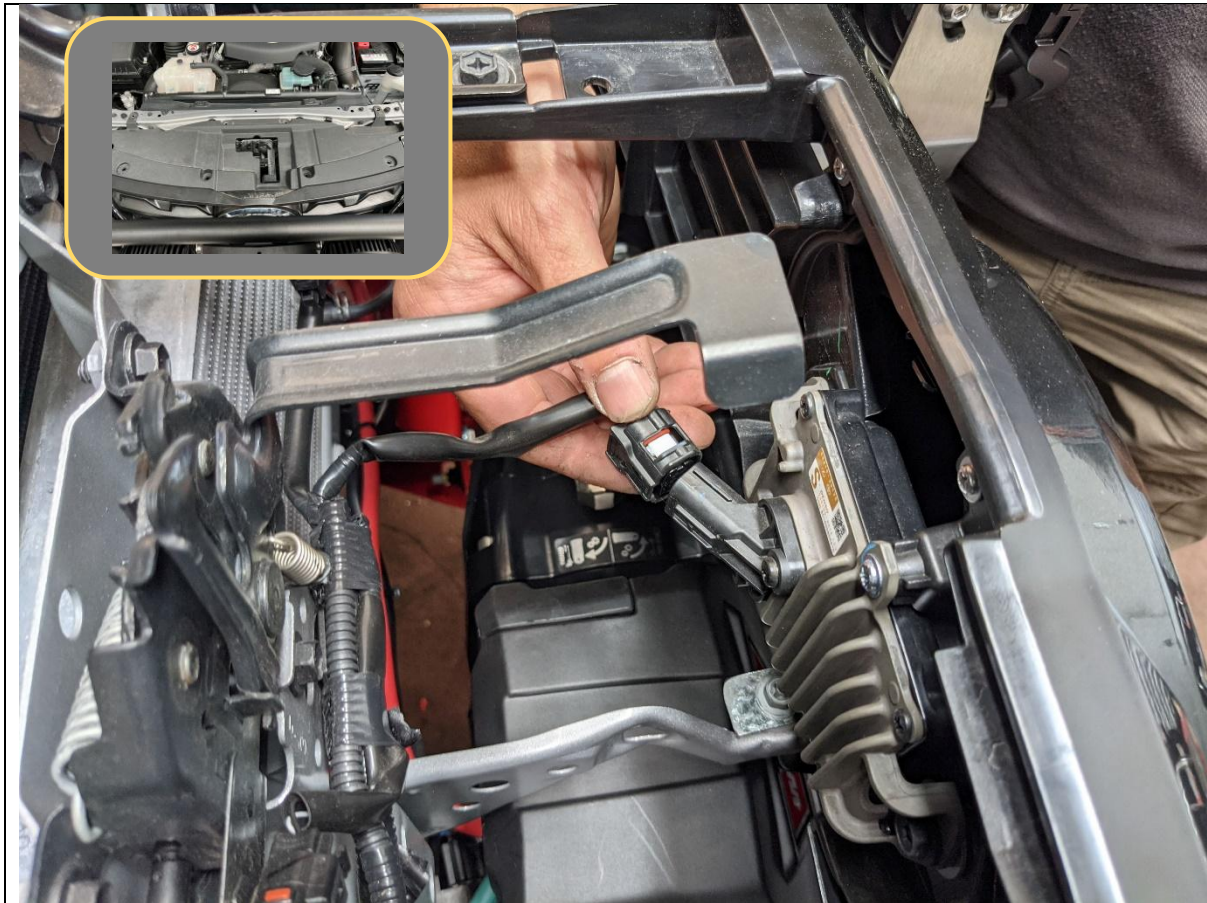

100. Re-connect all wiring harnesses to the adaptive cruise sensor, parking sensors and fog lights.

101. Replace the radiator shroud to top of grille, Secure with factory push center clips.

**TOOLS REQUIRED**

**FASTENERS**

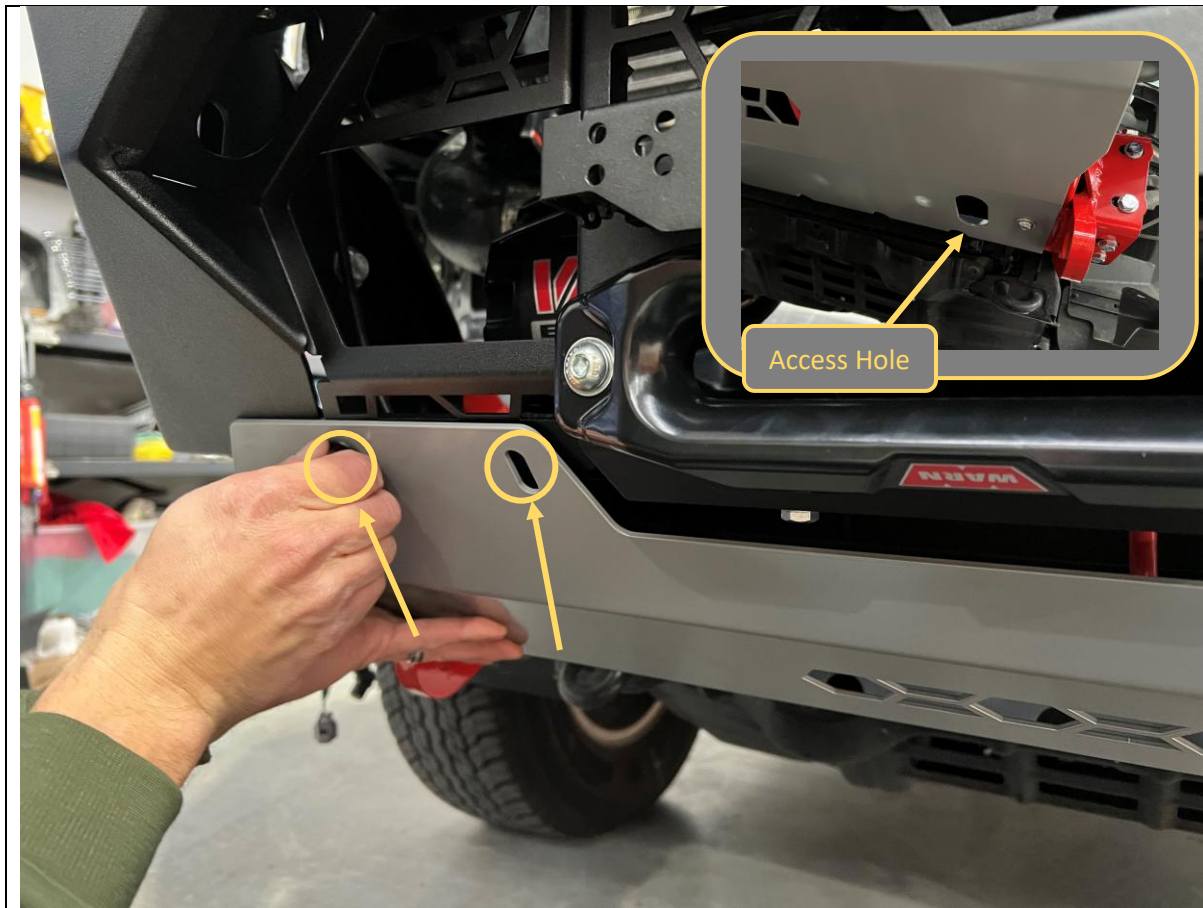

<p>102. Fit bash plate to vehicle.</p>	<p><b>TOOLS REQUIRED</b></p> <p>5mm Hex key 6mm Hex key 15mm Spanner</p>
<p>103. First secure the top of the bash plate to the bottom of bar, with the mesh panels sandwiched in between. Secure with M8x20 black button head bolts and black washers into the threaded inserts in the bar.</p> <p>104. Secure bottom of bash plate to mounts using M10x30mm Button head Bolt, Flat washer and M10 Flange Nut. Insert nut through access hole in bash plate as shown.</p>	<p><b>FASTENERS</b></p> <p>4x M8x20 Button head Bolt 4xM8 Flat washer</p> <p>2x M10x30 Button head Bolt 2x M10 Flat washer 2x M10 Flange nut</p>

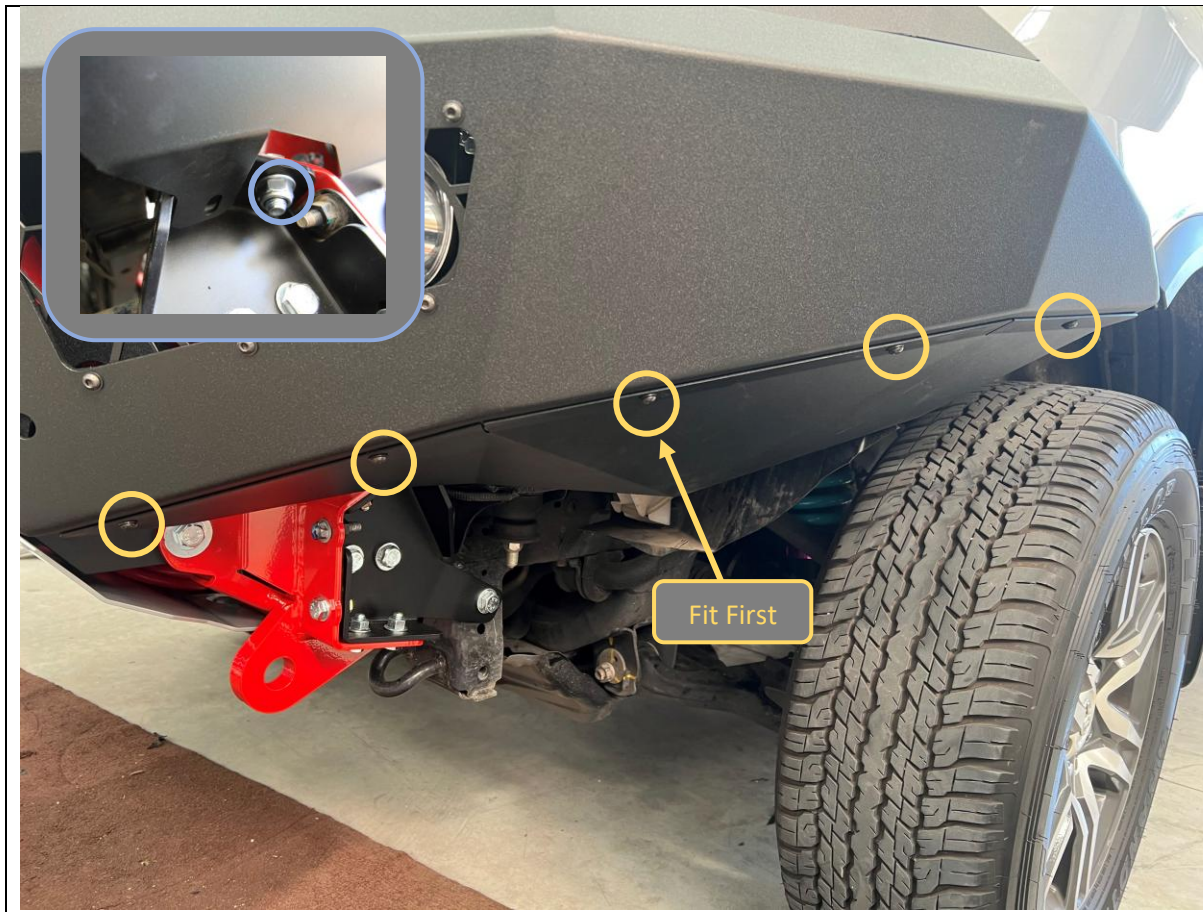

105. Fit side under panels to bar and secure with 5x M6x16 Button head bolts and M6 Flat washers, into M6 cage nuts fitted earlier.

Fitting center bolt first will make it easier to align panel to bar.

106. Secure the back corner of under panel to mount using M8x20 Hex bolt, Flat washer and M8 Flange Nut.

107. Repeat for other side of vehicle.

**TOOLS REQUIRED**

4mm Hex Key  
13mm Spanner / Socket

**FASTENERS**

10x M6x16 Button head bolt  
10x M6 Flat Washer  
  
2x M8x20 Hex head  
2x M8 Flat Washer  
2x M8 Flange nut



- 108. Mark where wheel arch liner intersects with side under panel with paint pen or another marker.
- 109. Create line offset approximately 20mm below intersection point.
- 110. Trim wheel arch liner to this line using utility Knife.
- 111. Insert wheel arch liner behind flange on side under panel.

**TOOLS REQUIRED**

Marker  
Utility Knife

**FASTENERS**



<p>112. Fit the logo plate to the front of the bar as shown.</p> <p>113. Fit the Compliance plate in a visible location on the underside of the bar. We recommend placing it on the bottom of the center bash plate.</p>	<p><b>TOOLS REQUIRED</b></p>
	<p><b>FASTENERS</b></p>

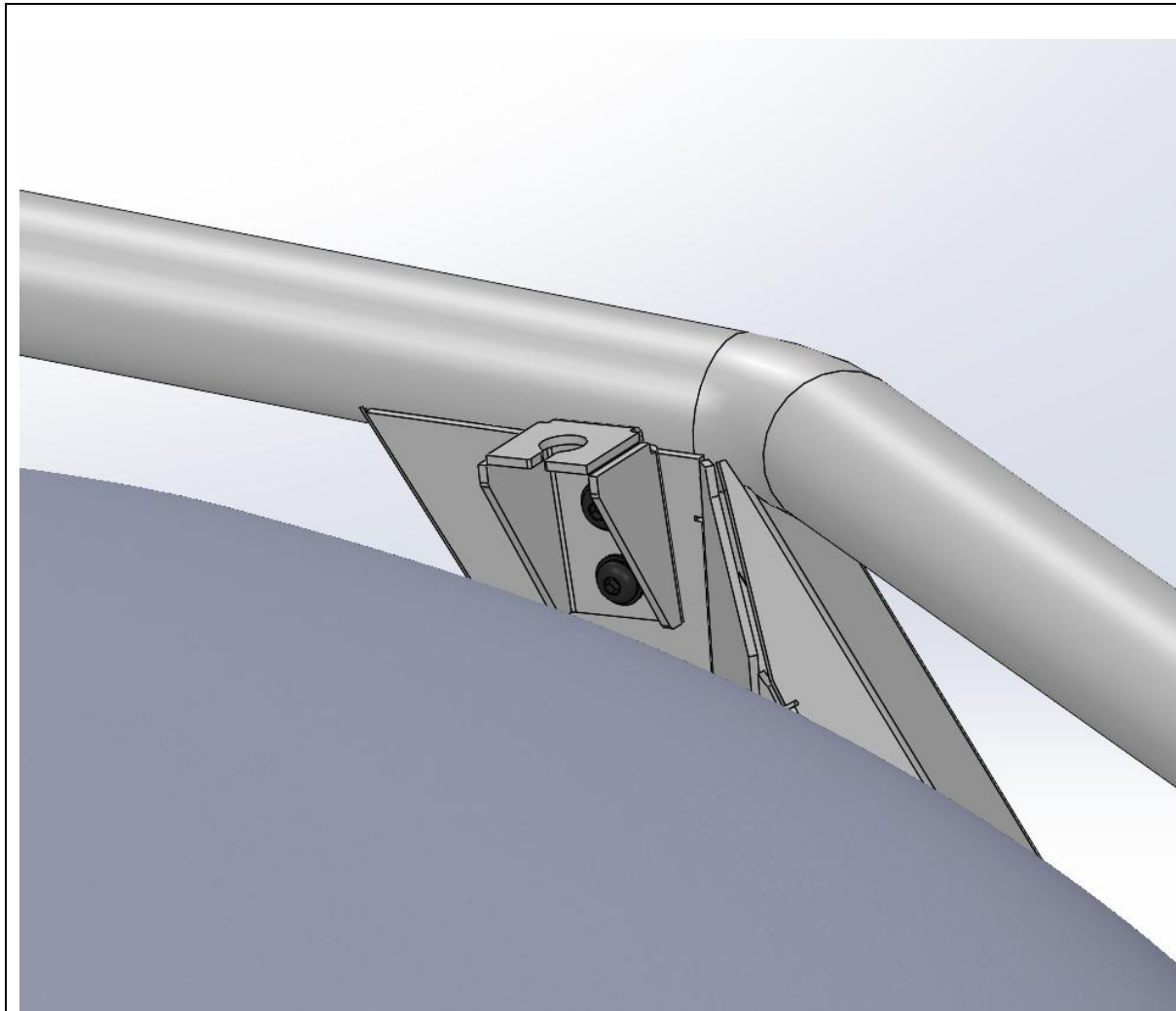

- 114. **Toro only.** If required fit the Antenna Brackets to the captive nuts in the uprights using supplied M8x20 Button head bolts and Flat Washers
  
- 115. **Toro only.** If not fitting Antenna brackets, fit bolts to captive nuts to preserve threads. Supply Antenna brackets to customers for future use
  
- 116. Review fitment and double check all bolts are tight.

**TOOLS REQUIRED**

5mm Hex Key

**FASTENERS**

2xM8x20 Black Button Head  
Screws  
2x Black Flat Washer

Per side



**Congratulations!**  
**Head for the tracks and enjoy your newly protected Toyota Fortuner!**